



HIAB ix.162 HI PRO

BASIC DATA
2022.09

HIAB iX.162 HIPRO

BASIC DATA

| Technical data | HIAB iX.162 HIPRO B-2 | HIAB iX.162 HIPRO BS-2 | HIAB iX.162 HIPRO BSS-2 | HIAB iX.162 HIPRO B-3 |
|--|-----------------------|------------------------|-------------------------|-----------------------|
| Mdyn (kNm) | 186 | 186 | 183 | 186 |
| Max. lifting capacity (kNm) | 157.3 | 157.5 | 159.2 | 153.2 |
| Lifting capacity (tm) | 16.1 | 16.1 | 16.2 | 15.6 |
| Outreach – lifting capacity, standard (m - kg) | 8.5 – 1860 | 8.2 – 1940 | 7.5 – 2120 | 10.7 – 1360 |
| Outreach – lifting capacity, manual extensions (m-kg) | 10.7 – 1400 | 10.4 – 1460 | – | 12.8 – 1080 |
| Hydraulic outreach, standard (m) | 8.8 | 8.5 | 7.9 | 11 |
| Outreach, manual extensions (m) | 11 | 10.7 | – | 13.2 |
| Lifting height above installation level, hydr/man (m) | 11.2 / 13.4 | 10.9 / 13.1 | 10.3 | 13.4 / 15.6 |
| Rec. fixed oil flow (l/min) | 70 – 90 | | | |
| Rec. variable oil flow (l/min) | 70 – 120 | | | |
| Working pressure (Mpa) | 33.3 | | | |
| Oil in tank (l) | 100 – 200 | | | |
| Oil in Cyclon tank (l) | 57 | | | |
| Tank capacity (l) | 116 – 224 | | | |
| Tank capacity Cyclon (l) | 61 | | | |
| Slewing angle (°) | 415 | | | |
| Max slope viable at full capacity (°) | 5.0 | 5.1 | 5.0 | 5.0 |
| Slewing torque, gross (kNm) | 20.5 | | | |
| Slewing speed 80 (°/s) | – | | | |
| Slewing speed (°/s) | 16.7 | | | |
| Lifting speed at standard hydraulic outreach (m/s) | 1.6 | 1.6 | 1.4 | 2 |
| Height in folded position (mm) | 2264 | | | |
| Width in folded position (mm) | 2476 | 2452 | 2476 | 2476 |
| Install space required with hose and pipe kit (mm) | 834 | 834 | 834 | 942 |
| Crane in standard version without stabiliser system (kg) | 1580 | 1570 | 1520 | 1710 |
| Frame attachments (kg) | 26 | | | |
| Stabiliser system (kg) | 216 – 385 | 216 – 386 | 216 – 387 | 216 – 388 |

This table shows a few examples of models, and represents some of all options available. With the opportunity to configure your crane, we can provide you with a crane perfectly tailored to your needs.

Please contact your local dealer for more information on the variety of options we can offer.

HIAB HIAB iX.162 HIPRO

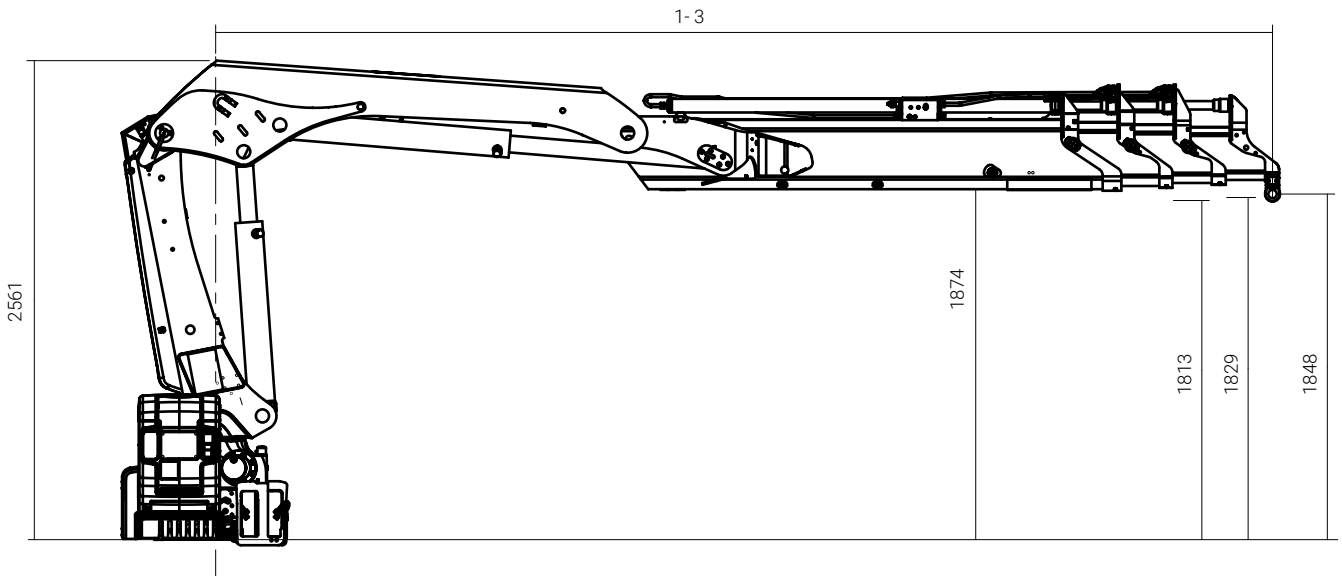

| 1-3, OUTREACH | | | | |
|---------------|-----------|-------|-------------|-------|
| Ext. | Hyd. ext. | | + Man. ext. | |
| | Min | Max | Min | Max |
| B-3 | 5049 | 10999 | 5049 | 10999 |
| B-2 | 4964 | 8814 | 4964 | 8814 |
| B-1 | 4879 | 6779 | 4879 | 6779 |

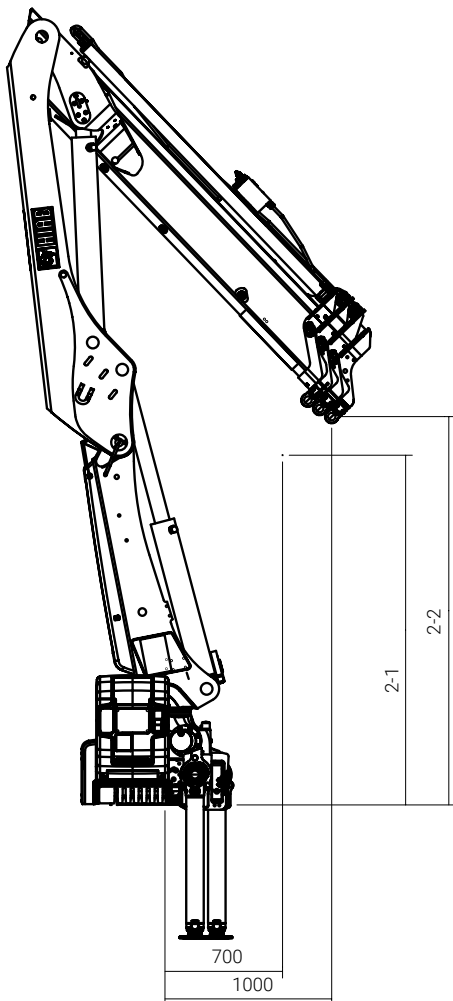

Hook position – close

| EXTENSION | 2-1 | 2-2 |
|-----------|------|------|
| B-3 | 2129 | 2329 |
| B-2 | 2225 | 2324 |
| B-1 | 2321 | 2540 |

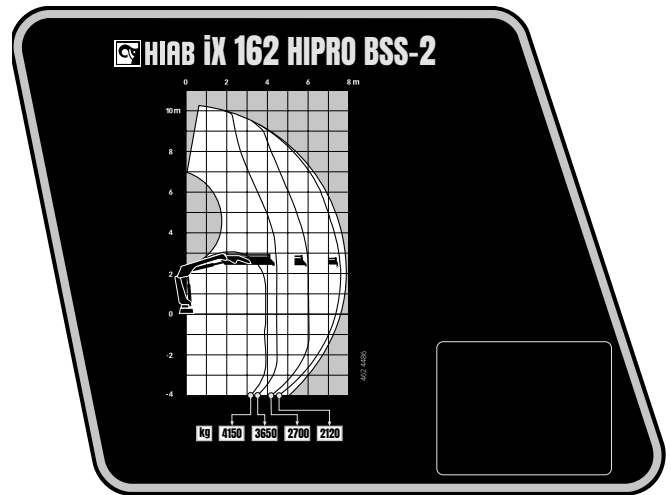
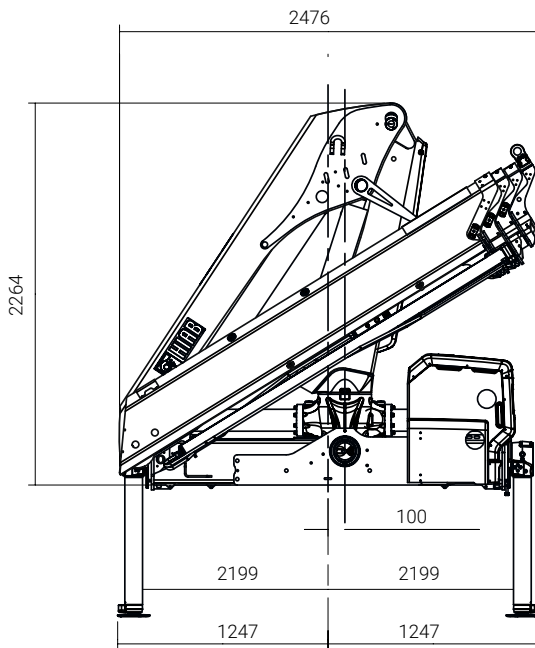

Disclaimer. We reserve the right to make changes. Illustrations, drawings and data are not always in accordance with the latest version or standard model in production. The models in the pictures may present special equipment or colours.

BD-HIABI162HIDUO-EN-WW_220916

BUILT TO PERFORM

Hiab is a leading provider of smart and sustainable load handling solutions. We are committed to delivering the best customer experience every day with the most engaged people and partners. Hiab's premium equipment includes HIAB, EFFER and ARGOS loader cranes, MOFFETT and PRINCETON truck mounted forklifts, LOGLIFT forestry cranes, JONSERED recycling cranes, MULTILIFT skiploaders and hooklifts, GALFAB roll-off cable hoists, and tail lifts under the ZEPRO, DEL and WALTCO brands. As the industry pioneer, Hiab continues to make load handling smarter, safer and more sustainable to build a better tomorrow.

Hiab is part of Cargotec Corporation.

www.hiab.com

